



## Seal Handling Guide

---

---

■ Seal Handling Guide	—————	G-2
1. Handling NOK's Standard Oil Seals	—————	G-2
2. Handling NOK's General Oil Seals	—————	G-9

# G. NOK OIL SEAL HANDLING GUIDE

Even if you correctly designed or selected the shaft and housing into which the oil seal is installed, rough handling or assembly of the oil seal may result in the oil seal being unable to function as intended. This chapter discusses proper handling of oil seals during assembly and replacement. Before using an oil seal, read and follow the relevant instructions.

## ■ Handling NOK's Standard Oil Seals

Use the following as guide to proper seal handling.

### 1. Packaging

Oil seals are packaged in bags, rust-preventing paper, or corrugated cardboard boxes, depending on the size or quantity. The packaging is necessary to protect the oil seal against rust, damage, and foreign matter. Only open the package immediately before use.

### 2. Storage

#### (1) Storage Precautions

Follow these instructions when storing oil seals.

- ❶ Do not open the package until needed, as the oil seals may become contaminated or damaged.
- ❷ Do not expose the oil seal to direct sunlight for extended periods of time. Ultraviolet rays may hasten the deterioration of rubber.
- ❸ Do not place the oil seal in locations where it may be exposed to excessive moisture. Rust can form on the external metal or garter spring of the oil seal.
- ❹ Do not place the oil seal near heat sources, such as a boiler or stove. Heat accelerates the deterioration of rubber.
- ❺ Avoid hanging the oil seal on nails or steel wires, or dangling the oil seal using a cord. The oil seal may be deformed, or its sealing edge may be damaged.
- ❻ When storing the oil seal after opening its package, take care to protect it from rust, as well as foreign particles such as dust and sand.
- ❼ Avoid excessive shock during handling or transit to prevent deformation of the oil seal or dislodging the garter spring.

#### (2) Storage Time

The table below shows the maximum shelf life of properly stored oil seals.

Product	Material	Shelf Life
100% Rubber Products	Nitrile rubber (NBR)	10 years
	Acrylic rubber (ACM)	20 years
	Silicone rubber (VMQ)	20 years
	Fluorocarbon rubber (FKM)	20 years
Rubber/Metal Bonded Products	Nitrile rubber (NBR)	10 years
	Acrylic rubber (ACM)	10 years
	Silicone rubber (VMQ)	10 years
	Fluorocarbon rubber (FKM)	10 years

### 3. Protect the Shaft and Housing

Take care not to damage the shaft and housing before assembly, as leaks may occur. Use a carrying jig to prevent the finished surfaces of the shaft and housing from contacting other objects, as indicated below.

Figure 1 shows a storage jig for housings. Each housing is placed so that it leans against individual partitions to prevent damage. This jig is made from plastic to prevent the metal part from being scratched.

Figure 12 shows a storage/transport cap jig for shafts. Placing this plastic cap over the shaft prevents the shaft from being damaged.

Figure 1: Housing Storage Jig

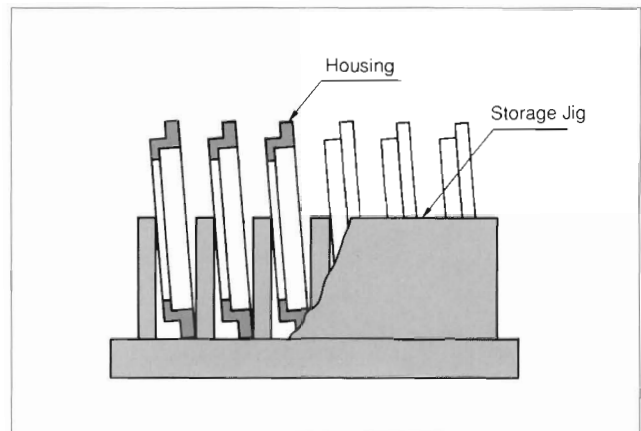
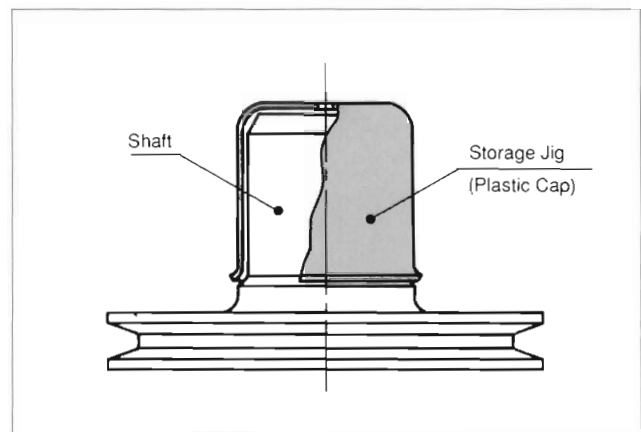

Figure 2: Shaft Storage Jig



- The storage periods shown on the left are applicable to products sealed in standard packaging and stored in a cool dry place away from direct sunlight.
- The indicated storage periods do not account for rust formation on the metal parts of bonded seal products, since rust is largely influenced by the storage environment.
- Before using an oil seal that has been kept in storage for an extended period of time, check that it is free from rust.
- A white powder may appear on the surface of rubber products (known as "bloom phenomenon"). This does not affect oil seal performance.

## 4. Preparation Before Assembly

### (1) Oil seal

- 1 Do not use an oil seal that has dust or sand on it, as leakage may occur.
- 2 Do not scrape the sealing edge of the oil seal with nails or other hard objects. The sealing edge is the most important part in determining oil seal performance.
- 3 For an oil seal having two or more lips, such as the T type and K type oil seals, apply mineral based lithium grease (for example, Sealube S1 made by NOK) between the lips to lubricate the lips. (See Fig. 3.).
- 4 For an oil seal having only one lip, such as the S type, V type, and TCK type oil seals, coat the seal lip edge with grease to lubricate the lip.

For recommended greases, refer to page K-11.

Figure 3: How to Apply Grease

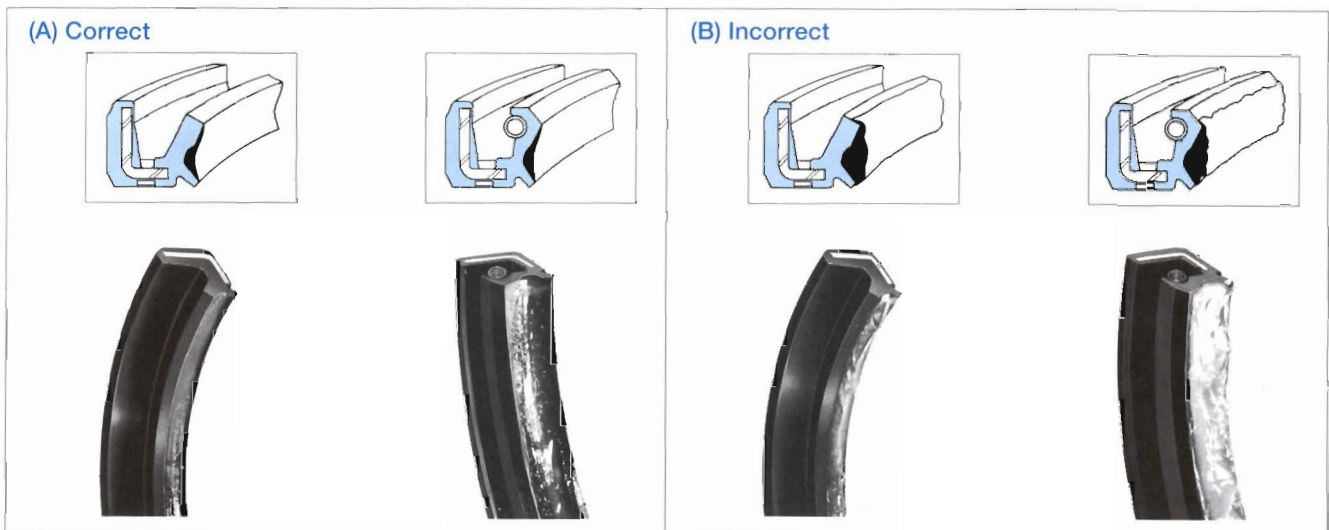

Apply the grease so that it does not overflow past the lip, as shown in (A).

Applying too much grease, as shown in (B), may cause overflow during assembly that may be mistaken for leakage.

### (2) Shaft and Housing

- 1 Check that the shaft surface and the housing bore are free of rust preventatives, dust and grit. If these impurities exist, clean thoroughly to remove. If oil or gasoline is used for cleaning, carefully wipe the area dry.  
Also, spraying compressed air is effective, as it cleans areas that are not readily visible. Residual oil or gasoline on the shaft or the housing bore can result in the oil seal swelling to an incorrect size, which may cause leaks.

- 2 Check that the inner surface of the housing bore and the chamfered area, as well as the shaft end and the shaft surface into which oil seal is inserted are free of defects and burrs. Remove any irregularities with emery paper to prevent damage to the sealing edge or outer surface during assembly.
- 3 Check that the shaft surface that the sealing edge will contact is free of defects and rust, thus preventing leaks from those causes.

## 5. Installing the Seal Into the Housing Bore

### (1) Installing the Seal

- ❶ Orient the seal so that the seal lip faces the fluid to be sealed, as shown in Figure 4.
- ❷ Install the seal squarely using the jig as illustrated in Figure 5.

Figure 4: Orientation of the Seal

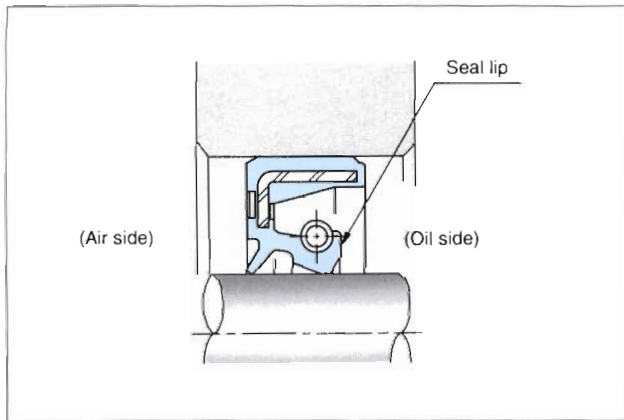

Figure 6 shows improper installation jig use. The oil seal will be deformed by the jig pressure and resistance of the seal/bore press-fit. When installing the oil seal, there is no need to apply force at the area near the lips.

Figure 5: Use examples of assembling jig (applicable to the fit with rubber or metal)

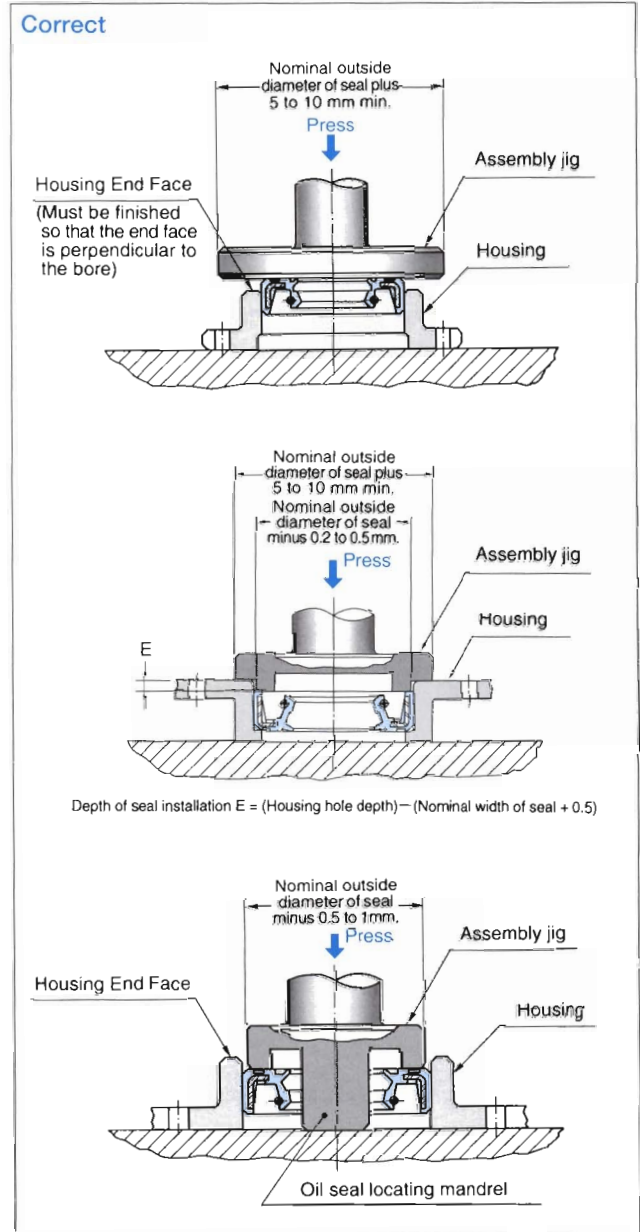
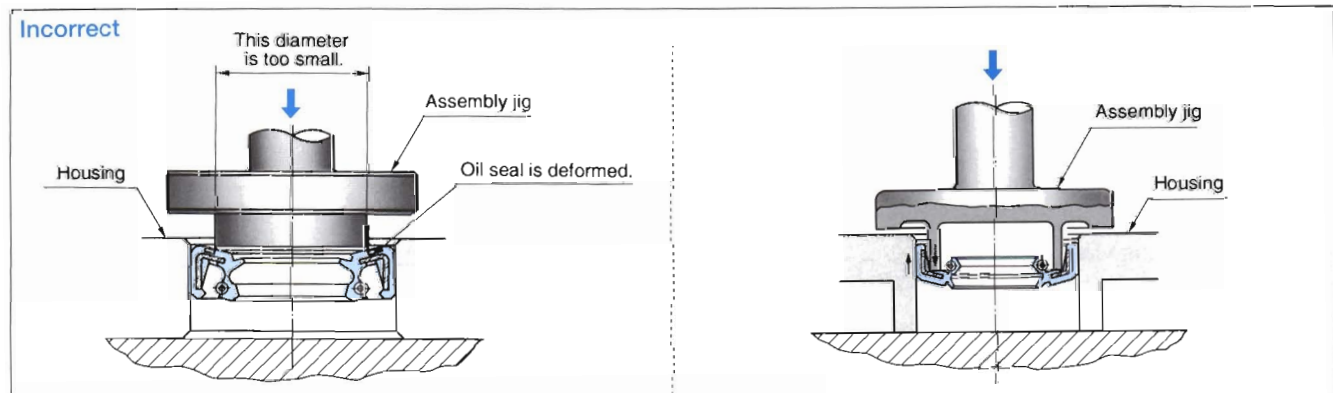
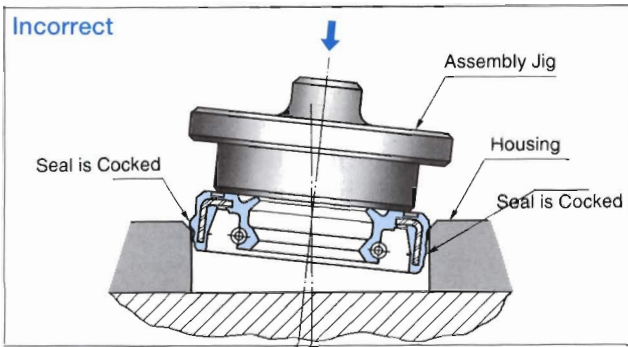

Figure 6: Examples of Improperly Designed Assembly Jigs



- 3 Place the oil seal in the housing bore in a horizontal position, and then press the oil seal in uniformly. Pressing a cocked seal in with excessive force (see Fig. 7) deforms the oil seal, which in turn causes leakage.

Figure 7: A Cocked Seal Installation Example



- 4 For oil seals with a rubber OD, press the assembly jig twice in succession to let the oil seal settle firmly at the desired depth of installation in the bore.

- 5 If a press is not available, use a full-sized strike plate as shown in Figure 8, and drive the entire circumference evenly with a hammer to install the oil seal squarely into the bore. Do not strike the oil seal directly with a hammer, as shown in Figure 9.

- 6 Figure 10 shows the press forces required to properly install an oil seal.

Figure 8: Installing a Seal Without a Press

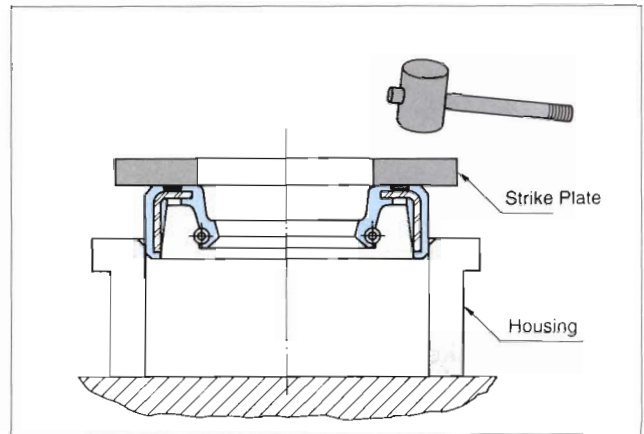

Figure 9: Damage Caused by Direct Hammer Strikes

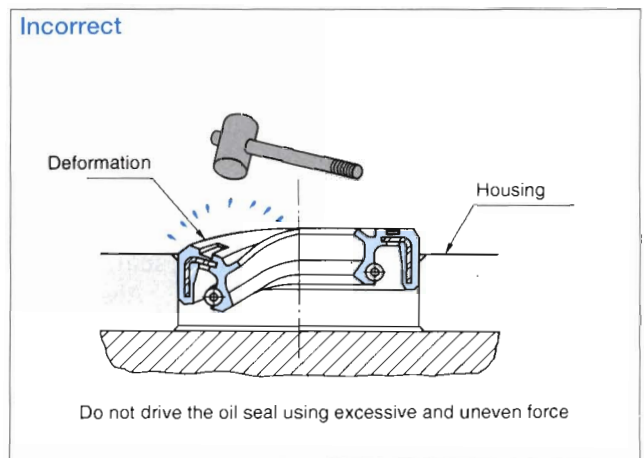
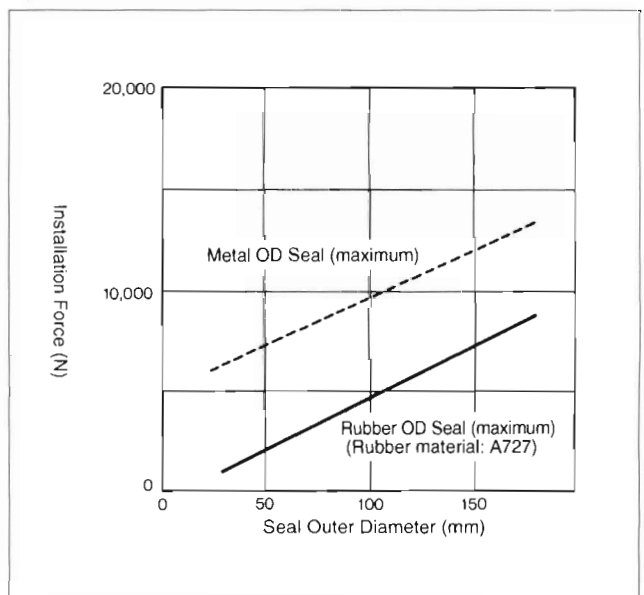

Figure 10: Seal Installation Force Requirements (Base on 100mm/min)



### (2) Assembly Into a Split-Type Housing

As mentioned on page F-14, avoid using a split-type housing if possible. If a split housing must be used, first assemble the housing, then install the seal in order to prevent cocking the seal.

Leaks can occur at the mating surface areas of the split housing. Apply a coat of liquid gasket sealant to the split area to prevent this leakage.

### (3) Liquid Gasket Sealant

When a metal OD seal is used, it is necessary to apply a coat of liquid sealant to prevent the bore ID surface from developing flaws during oil seal replacement, or when a metal OD seal is used and the application is subjected to internal pressure. Observe the following precautions when using sealants.

- 1 Apply a thin coating of the sealant to the bore ID surface of the housing, and wipe off any excess. Leakage can occur if the lip or the shaft surface is contaminated with sealant.
- 2 Full-curing or extremely strong sealants require excessive force to remove the oil seal, usually resulting in damage to the housing. Always use semi-drying liquid gasket sealant.

## 6. Installing the Seal Onto the Shaft

- 1 Apply a thin coating of lubricant or mineral oil based lithium grease (for example, Sealube S1 made by NOK) to the shaft surface and the chamfer area. The seal should be smoothly inserted onto the shaft. Take care not to cause lip turn-under during this operation.
- 2 Align the center of the seal with the shaft centerline, and carefully insert the shaft into the oil seal.
- 3 When installing a pre-assembled housing and seal onto a shaft, or inserting a long shaft into a preassembled seal/housing, the seal lip can be damaged due to shaft contact during this awkward operation. See sketch (A) in **Figures 11 and 12**. Avoid this damage by installing the seal only after the shaft and housing are assembled. If this is impossible, use an installation guide for the housing or shaft, as illustrated by (B) in **Figures and 12**.

Figure 11: Assembling a Heavy or Awkward Housing

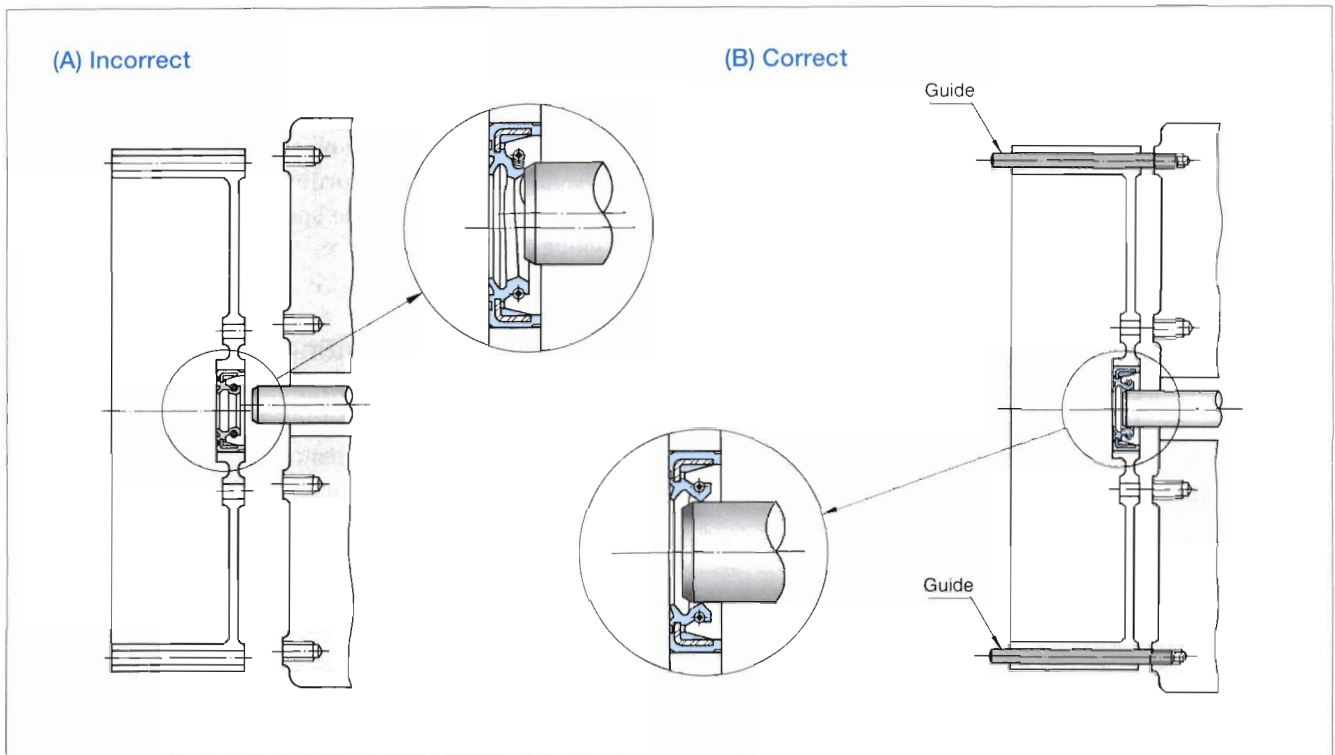

Note: When assembling a heavy housing by hand, as illustrated in (A), the shaft may come into contact with the lip and deform it, due to the difficulty of aligning the shaft and oil seal. For this reason, use a guide by taking advantage of the mounting bolt holes, as illustrated in (B).

Figure 12: Assembling a Long or Awkward Shaft

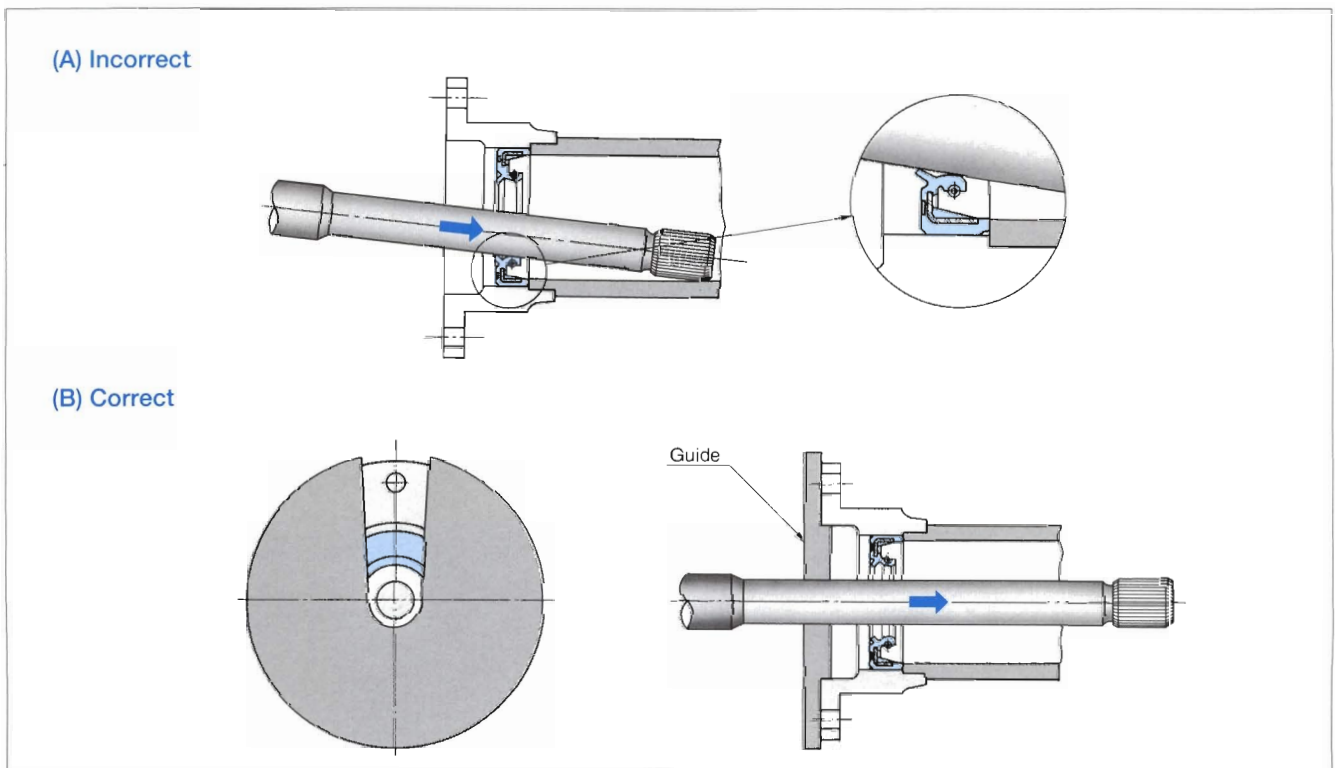

Note: If a guide is not used, part of the lip rubs against the shaft, damaging the sealing edge, as illustrated in (A). The use of the guide allows you to insert the shaft accurately, as illustrated in (B). Select a plastic guide to prevent the shaft surface from being scraped.

- ④ If the shaft has keyways or splines, the seal's lip edge may be damaged. Cover the shaft as illustrated in Fig. 13.

Figure 13: Protective Keyway/Spline Cover

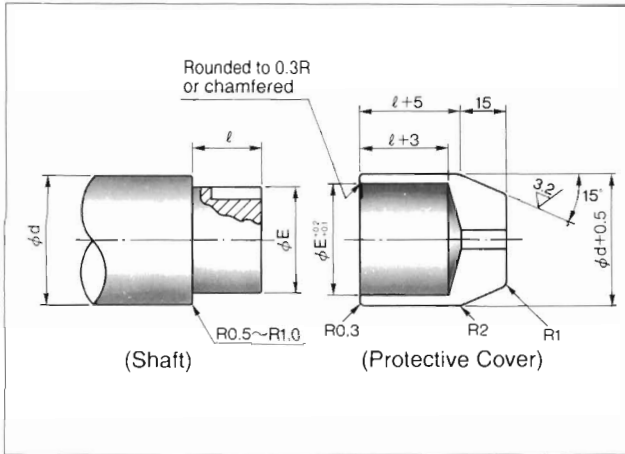

## 7. Oil Seal Replacement

- ① Always replace used oil seals when disassembling the oil seal area (i.e., removing the shaft).
- ② When removing an oil seal, take care not to damage the housing bore surface.
- ③ When replacing a new oil seal, place a 2mm shim in the housing hole in order to prevent the seal lip from riding in the same spot on the shaft as the previous seal.

## 8. Cleaning and Painting

- ① Cleaning the machine with oil or gasoline may cause the lip material of an exterior seal to swell, resulting in reduced seal performance.
- ② When painting the machine with an exterior seal, use care not to get paint on the oil seal or the shaft surface.



## ■ Handling NOK's General Oil Seals

The following explains how to handle general oil seals. Handle D-type oil seals in the same manner as standard oil seals.

### J-Type (PTFE) Oil Seal

The sealing edge of a J type seal is more susceptible to installation damage than seals with standard synthetic rubber lips. Observe the following precautions when mounting J type oil seals onto the shaft.

- 1 Check that the shaft end is free of burrs or other defects.
- 2 Use an installation jig when there are keyways or splines on the shaft. (Refer to Fig. 8 on page G-8.)
- 3 Insert the shaft in the direction indicated in Fig. 14.

Figure 14: Shaft Assembly Direction

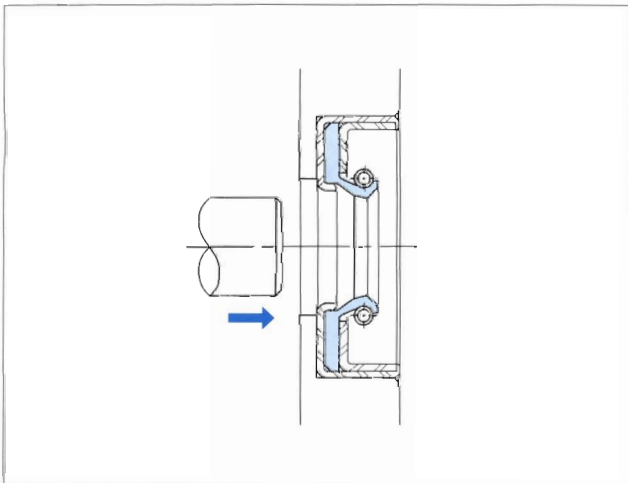
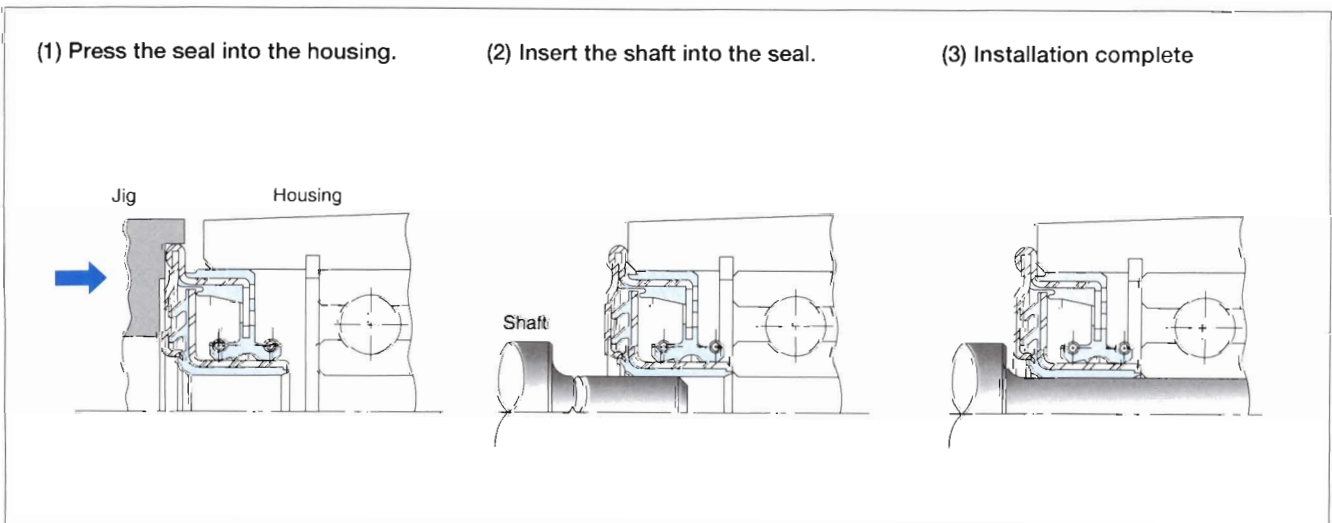

Figure 15: Mounting a QLFY-Type Seal



### OC-Type Oil Seal

The seal lip and press-fit area of OC type seals are "inside out" (reversed) relative to those of standard oil seals. Nevertheless, handle this seal in the same manner as standard oil seals.

The lip is located on the outer circumference. Protect the outer peripheral lip during transit or storage.

### QLFY-Type (With Integral Shaft) Oil Seal

The QLFY type seal has an integrated shaft (known as a unitized design). Mount this oil seal as a one-piece structure.

- 1 Use a jig as illustrated in Fig. 15 to press the QLFY seal into the housing bore.
- 2 Insert the shaft.

### VR-Type (End Face) Seal

Mount the VR type seal so that the fluid to be sealed is outside the lip perimeter, as illustrated in Fig. 16. Apply a thin coating of grease to the sliding face of the lip before mounting. It is not necessary to put grease on the inner fixed face.

Figure 16: Proper Orientation of VR Type (End Face) Seals

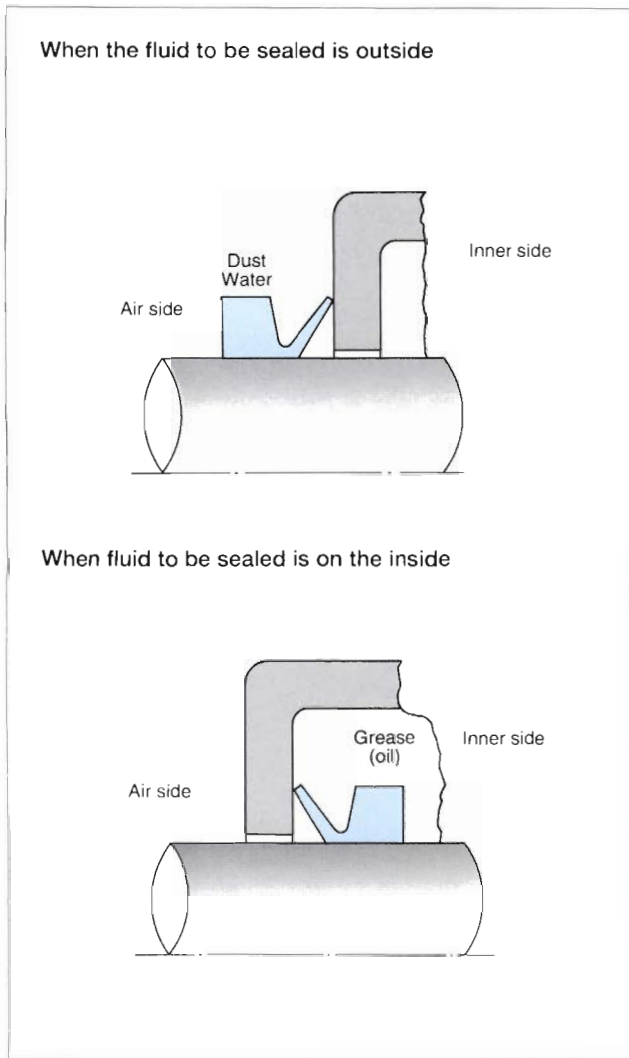

### Z-Type Oil Seal

Mount the Z type seal into the grooves so that the perimeter of the oil seal is seated as evenly as possible. Do not apply a coating of grease or oil to the trapezoidal grooves of the housing or the OD of the oil seal.

After the oil seal is mounted in the housing grooves, apply a light coat of grease to the seal lip, and then assemble the structure onto the shaft.

### SBB, Large-Diameter SB, Large-Diameter TB Type Oil Seals

#### ① Assembly Into the Housing

Insert the entire circumference of the oil seal evenly by using a jig, as illustrated in Fig. 17.

Figure 17: Seal Installation

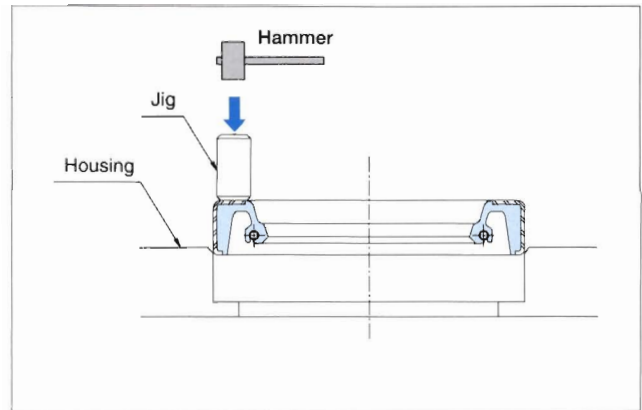

#### ② Installing the Shaft

Apply a coat of oil or grease to the shaft surface to facilitate shaft installation and for initial lubrication. Use a jig as illustrated in Figure 18 when there are keyways or splines on the shaft, or when the shaft end cannot be chamfered properly.

Figure 18: Shaft Installation

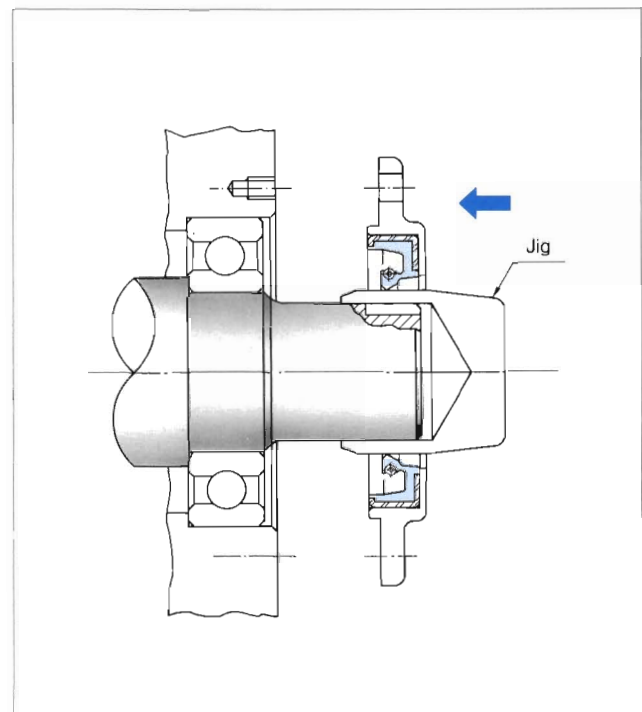

### Installing an MG-Type Oil Seal

An MG type oil seal (Fig. 19) is installed after it is cut through its OD, giving it flexibility to be used where a full-round seal cannot. Cut the oil seal as illustrated in Fig. 20. Connect the hooks of the garter spring, then put the garter spring in the lip pocket.

Observe the following precautions when assembling an MG type oil seal.

- 1 Place the cut splice side of the oil seal at the top.
- 2 Rotate the garter spring hook 45 degrees from the splice cut.
- 3 Adjust the spliced ends as evenly as possible. Do not apply any liquid sealant to the splice joint.
- 4 Place the pressure plate and tighten the bolts evenly. If the pressure plate is a split-type design, stagger the split lines 90 degrees to the seal splice.

### OKC3, MO, MOY Type Oil Seals

OKC3, MO, and MOY type oil seals are designed to seal by its outer diameter surfaces. Use care not to deform the outer lips or damage the sealing edges during transit or storage.

- 1 Do not transport the oil seal by rolling it.
- 2 Do not store the oil seal standing on its edges or leaning it against something.

Figure 19: MG Type Oil Seal

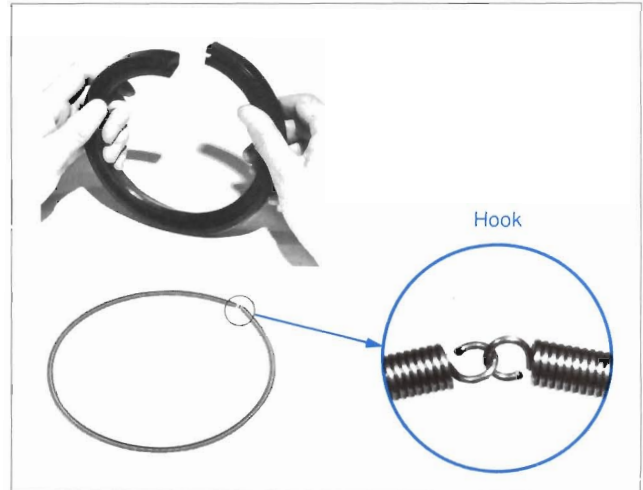

Figure 20: Cutting the MG Seal

